

## GLASS LINED STEEL RESERVOIRS



CJSC "Zavod Santeks" is a Belarussian enterprise with 10year experience in industrial production in the field of metal processing and glass-coating (enameling)

Plant territory: 15000M<sup>2</sup>

Machinery facilities: more 120 machines and equipment

Number of employees: 200 people

CJSC "Zavod Santeks" offers a full range of design, manufacturing and installation of glass-coated tanks.

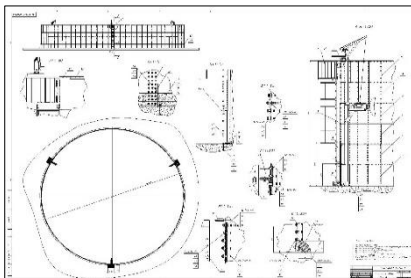

## Mounted reservoirs

Fire tanks  
(Russian Federation)



Silos tanks  
(Republic of Belarus)



## The volume of the GLS-tanks available from 5 to 30000 m<sup>3</sup>

### The advantages of GLS tanks

- quick installation (reinstallation) and removal at any time of the year;
  - no need for cranes or other large equipment for construction;
  - minimize lost construction days associated with weather delays;
  - possibility of producing reservoirs in accordance with technical requirements of the Customer;
  - an esthetic appearance;
  - no welded joints (used bolting);
  - high corrosion resistance;
  - NEVER NEEDS PAINTING;
  - service life up to 50 years, the warranty period from 5 to 15 years;
  - remove graffiti easily;
  - lowest life cycle cost;
-

## Panels coating technology

The enamel powder is applied onto the steel sheets by electrostatic charging. The charging of the enamel powder is done by ion atmospheric components which are formed by a corona discharge at the tip of a spray pistol.

The enamel parts move preferably along the electric field lines to the panel.

After that, the panel with the applied powder comes into the enameling oven.

The enamel powder melts with the steel at about 840 C to a strong and permanent fusion.

We have the possibility to round the edges before enameling to prevent damage from improper installation. This ensures also that the edges are better surrounded by the enamel.

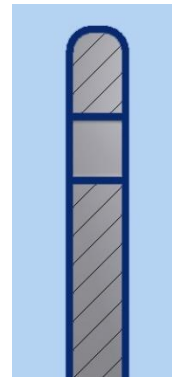
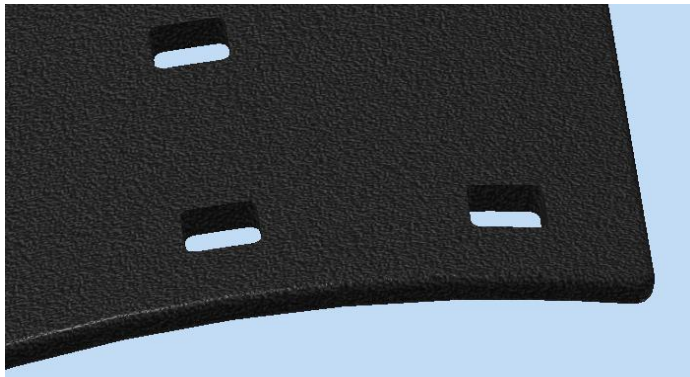

The view of panel after the process of glass-coating  
Steel panel is fully protected from the contact with stored materials and external influences



## Panels assembling technology

Glass lined steel panels panel  
Thickness: 4/5/6/7/8/10/12 mm  
Steel type: special enamel able,  
Steel 65G , DD14, St3  
Method: hot rolled

Panel bolts: Hot-dip galvanized with plastic head  
Dimension: M 12  
Strength category: 8.8  
Nut, washer: Hot-dip galvanized  
Nut cap: optional (in plastic)

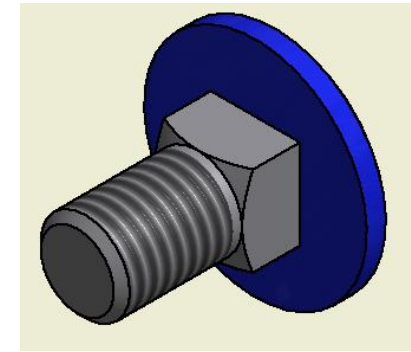
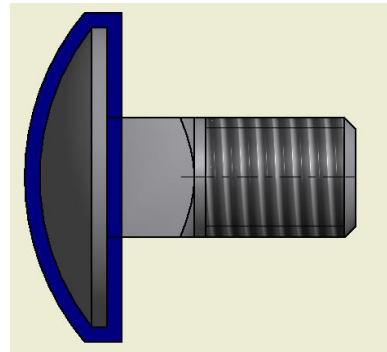

## Panels connection diagram

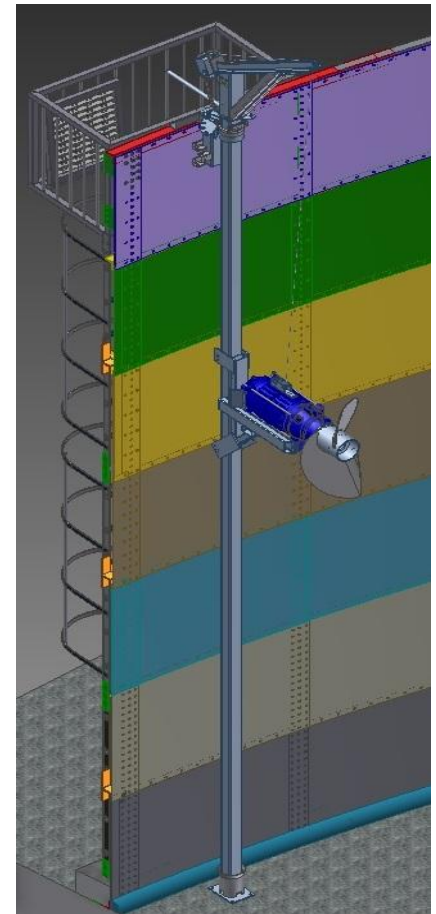
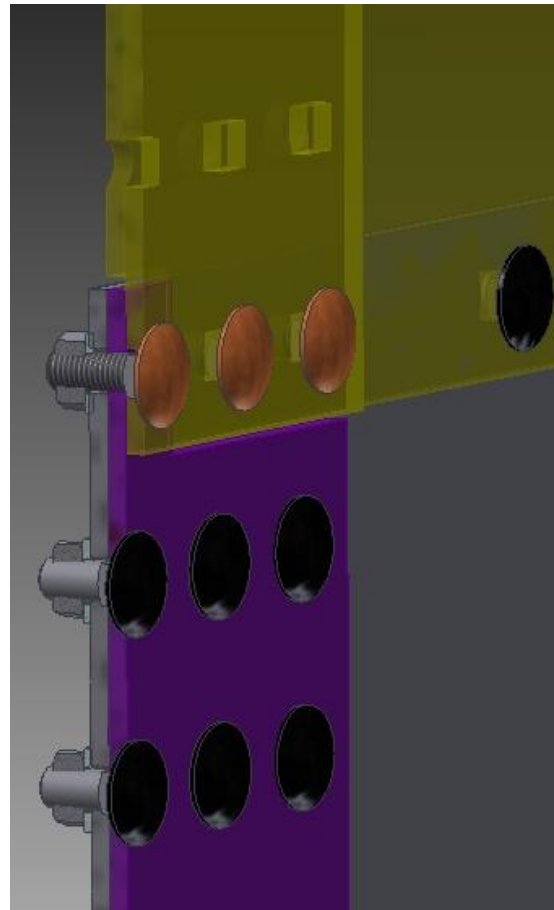
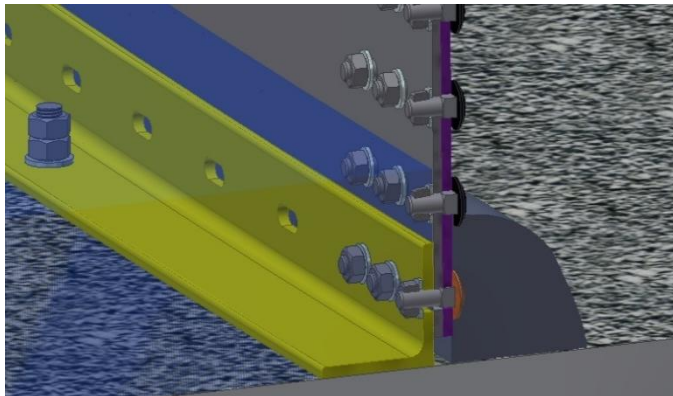
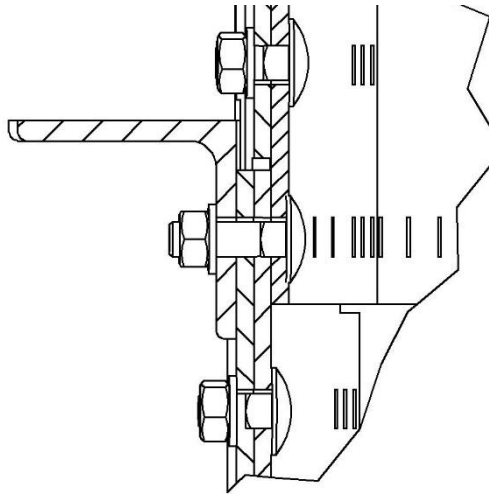

## The general ways of GLS tanks application

- Liquid manure



- Potable water

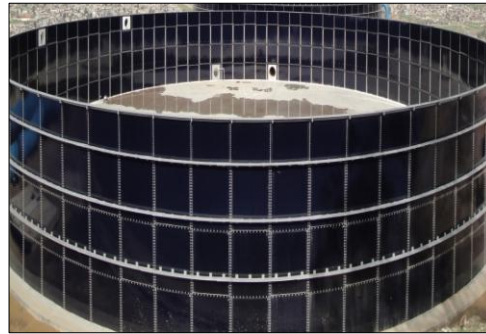

- Fish farming



- Fire tanks



- Wastewater treatment systems



- Biogas PROJECT

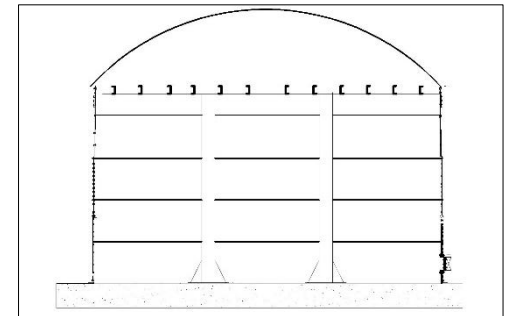



## Tanks production stages

1. Creating a full 3d model of a tank, according to Customers technical requirements

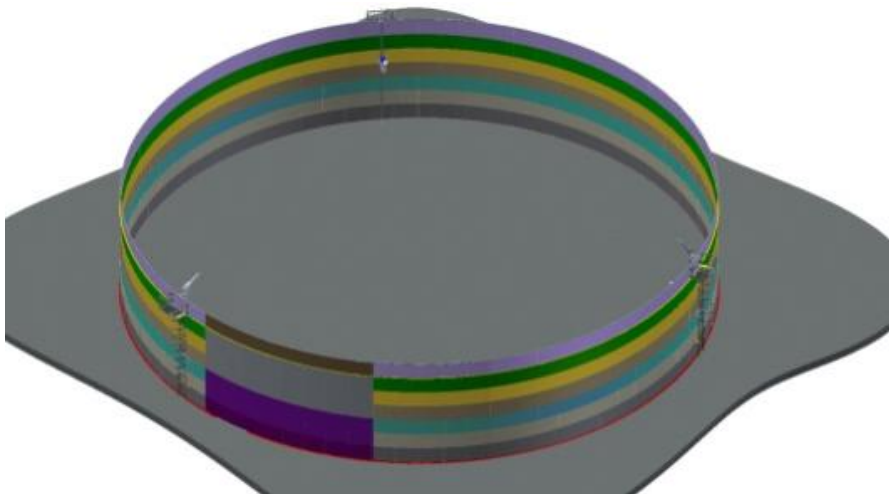

2. FEM Calculation with snow, wind, rust and internal liquid loads

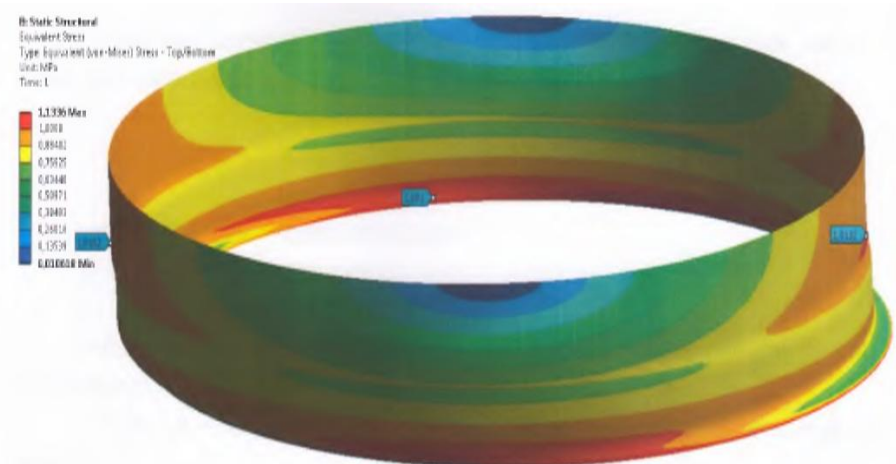

## Tanks production stages

3. Delivery of high-quality rolled steel



4. Laser line cutting with TRUMPF TRUMATIC L 3030. This line allows precision cutting up to 10 microns



5. Pickling and passivation panels



## Tanks production stages

6. Covering by chemically resistant glass-coating produced by FERRO (Holland), heating to temperature more than 870°C.

7. Quality control, inspection and packaging.





## Tank installation steps

1. Preparation of the concrete base of the tank



2. Installation of the base corner of the first tier





## Steps for installing tanks.

3.1. The assembly of the first tier and the formation of reinforced concrete belt

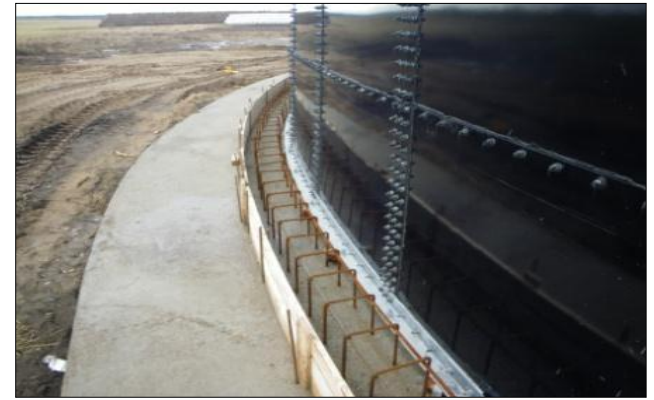

3.2. Assembling the next tiers with the installation of stairs



CJSC "Zavod Santeks" offers full cycle of design, manufacture, installation and warranty of glass-coated tanks

Contact information:

Yagor Nikitsin

[www.santex.com](http://www.santex.com)

zakazsantex@gmail.com

mobile: +375-29-6766359

---